



Dynamic Transducers and Systems

21592 Marilla St. • Chatsworth, CA 91311 • Phone 818-700-7818 • FAX 818-700-7880
www.dytran.com • e-mail: info@dytran.com

OG1050C.DOC
12-20-00

OPERATING GUIDE

MODEL 1050C

CHARGE MODE DYNAMIC FORCE SENSOR

This manual contains:

- 1) Specifications, Models 1050C
- 2) Outline/Installation drawing 127-1050C
- 3) Operating Instructions Model 1050C

SPECIFICATIONS MODEL 1050C DYNAMIC FORCE SENSOR

SPECIFICATION	VALUE	UNITS
SENSITIVITY	-18	pC/Lb F
WORKING COMPRESSION RANGE	5,000	Lb F
MAXIMUM COMPRESSION FORCE	15,000	Lb F
MAXIMUM TENSION FORCE [1]	1,000	Lb F
STIFFNESS	11.4	Lb/μ In
MOUNTED RESONANT FREQUENCY, UNLOADED	75	kHz
LINEARITY [2]	+/- 1	%F.S.
F.S. OUTPUT VOLTAGE, NOM.	5	VOLTS
MAX SHOCK, UNLOADED	10,000	G's
MAX. VIBRATION, UNLOADED	+/- 2500	G's
COEFFICIENT OF THERMAL SENSITIVITY	.03	%/°F
TEMPERATURE RANGE	-100 to +500	°F
ENVIRONMENTAL SEAL	WELDED/EPOXY	
CAPACITANCE, NOM.	18	pF
INSULATION RESISTANCE	1 X 10 ¹²	Ohms
CASE MATERIAL	STAINLESS STEEL	
WEIGHT	32	GRAMS
MOUNTING PROVISION, TOP AND BOTTOM	1/4-28 x .175 DEEP	
ELECTRICAL CONNECTOR, RADIAL	10-32 COAXIAL	

ACCESSORIES SUPPLIED: (1) MOD 6210 STEEL IMPACT CAP, (2) MOD 6204 1/4-28 MOUNTING STUD

NOTES:

[1] **Absolute maximum tension. Do not exceed in any case!**

[2] Percent of full scale or of any lesser range, zero based best fit straight line method.

OPERATING INSTRUCTIONS MODEL 1050C CHARGE MODE DYNAMIC FORCE SENSOR

INTRODUCTION

The 1050C force sensor is designed to measure compressive and tensile forces over a wide dynamic range, e.g., from 10 Lbs full scale to 5000 Lbs full scale over a very wide frequency range, (quasi static to 50 kHz.) This sensor can measure to 500 Lbs full scale in tension.

Thin x-cut quartz crystals held under very high preload, provide a charge output analogous to dynamic force inputs. The output polarity is negative-going for compression and positive-going for tension.

Model 1050C features an integral axial mounting stud (threaded boss) which protrudes from the bottom of the unit. The electrical connector is at the end of this stud.

DESCRIPTION

Refer to figure 1 below for a representative cross section of Model Series 1050C force sensor.

Series 1050C features an integral threaded (5/16-24 thread) mounting stud for convenient mounting where radial space is limited. As previously stated, the electrical connector is located at the bottom end of the stud.

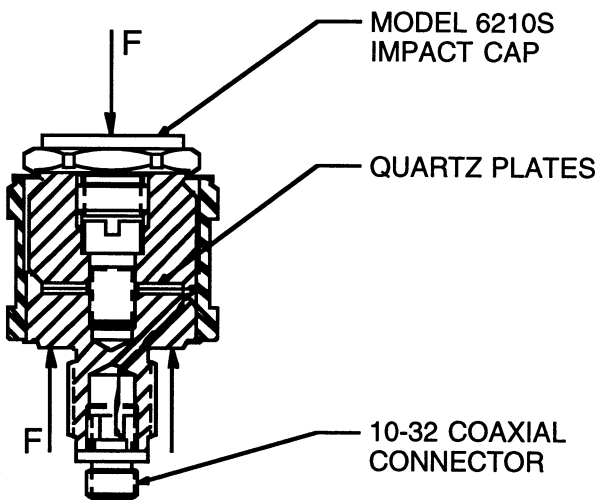

Figure 1: CROSS SECTION, MODEL 1050C

Model 1050C is recommended for use where radial space is limited such as in some drop shock testers, in impact hammers or when instrumenting shafts or pushrods where there is no space around the machine for the electrical connector to exit radially.

Referring to Figure 1, the upper threaded member (called the platen) distributes the force evenly across the quartz crystals while sealing the instrument against moisture and other contaminants. The very thin quartz crystals comprise a relatively small portion of the length of the sensor which results in a very high stiffness and high rigidity and natural frequency. The overall stiffness of this instrument is almost comparable to a solid piece of steel of similar dimension.

Refer to the Outline/Installation drawing, 127-1050C, supplied with this manual, for a dimensioned outline of Model 1050C.

THEORY OF OPERATION

Force compressing the load cell stresses the crystals causing an electrostatic charge to be generated which is exactly analogous to the applied force. This charge must be read out by a special type of amplifier called a Charge Amplifier because of its high impedance level. Refer to Figure 2 below.

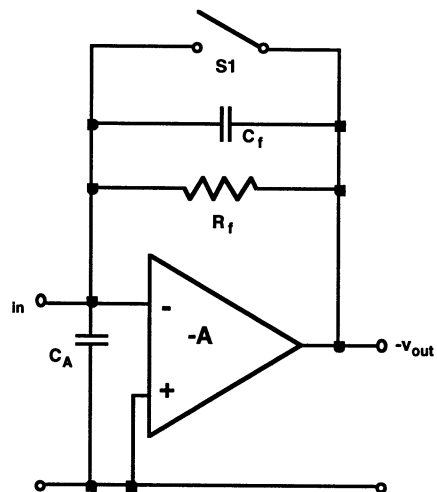

Figure 2: THE CHARGE AMPLIFIER

A charge amplifier has the ability to read out the very small signal from the force sensor without changing the signal. The charge amplifier converts the charge mode signal generated by the crystals to a low impedance voltage which may then be fed directly to almost any type of readout instrument.

A charge amplifier is essentially a very high input impedance inverting amplifier with infinite gain and with capacitive feedback. It can be shown that as the gain of the amplifier (-A) approaches infinity, the transfer function of the charge amplifier becomes:

$$V_o = \frac{-q}{C_f} \quad (\text{Eq 1})$$

Where:

- V_o is the output voltage (Volts)
- q is the input charge, (pC)
- C_f is the feedback capacitor, (pF)

This means that the sensitivity of the charge amplifier is determined by the value of the feedback capacitor only. Since the output voltage is fed back to the summing junction of the amplifier (the input terminal) the virtual input impedance is extremely high which means that the charge signal generated by the quartz crystals will not be drained away by the measuring device.

SIGNAL POLARITY

Compressive forces on these sensors (see Figure 1) produce negative-going output signals. This is because most charge amplifiers are inverting amplifiers and the output signal from the charge amplifier will be positive going for compressive loads. This is conventional.

By the same token, tension loads on the 1050C will produce positive-going output signals.

SENSITIVITY

The nominal charge sensitivity of Model 1050C is -18 pC/Lb.

CHARGE AMPLIFIER SELECTION

Dytran manufactures many different types of charge amplifiers to suit the needs of most any measurement requirement from the larger laboratory

type Model 4165 which features ranging and filtering plus standardization to the miniature in-line types 4751 and 4705 which adapt the 1050C to LIVM operation with constant current power units.

For laboratory measurements, the 4165 is recommended and for field use, the dedicated sensitivity n-line charge amplifiers may be a better choice.

Consult the factory for recommendations on the best type of charge amplifier for your measurement needs.

INSTALLATION

Refer to outline/installation drawing 127-1050C, supplied with this guide.

To mount model 1050C, it is necessary to prepare a flat smooth mounting surface of 5/8" minimum diameter. The surface should be flat to .0005 TIR for best results.

The mounting port must provide for room to connect the cable to the 10-32 connector at the end of the threaded integral mounting stud. Drill and tap a thru hole to accept the 5/16-24 thread on the mounting stud to secure the 1050C to its mounting surface.

Before mounting the 1050C, thread the sensor into the mounting port and examine the fit of the mounting surfaces. They must meet parallel, i.e., a wedge must **not** be formed between these surfaces. Also, at this time, inspect the mating surfaces for foreign particles which may become lodged between these surfaces and clean if necessary. It is important that the mating surfaces meet squarely and intimately with no particles of foreign matter of any kind included between them. Foreign particles included between mating surfaces could damage the sensor and/or modify the sensitivity of the sensor.

When you are satisfied that the surfaces are square and clean, place a thin layer of silicone grease on one of the surfaces and thread the force sensor place, torquing it in place with 25 to 30 Lb-inches of torque to secure.

For most impact applications, the Model 6210S (steel) impact cap will be utilized. This cap is threaded into the platen (top surface of the force

sensor). Thread this cap securely into the tapped hole in the platen, again inspecting for foreign particles between mating surfaces and clean if necessary. For more permanent installations, thread locking compounds may be used to secure the installation. Use these compounds sparingly.

For a slightly higher resonant frequency, the aluminum cap, Model 6210A, may be a better choice in some applications.

Connect the sensor to the charge amplifier using Series 6010AXX cable (10-32 to 10-32) or Series 6011AXX (10-32 to BNC plug), depending on the connector called for by the power unit. Tighten the cable lock ring snugly by hand. Do not use a pliers or vise grips on these cable lock rings.

OPERATION

After connecting the cable from the sensor to the charge amplifier, if the charge amplifier is the laboratory type, press the reset button which should zero the output voltage. You are now ready to select your range, set the discharge time constant and make the measurement.

If you are using an in-line charge amplifier, there is no reset button so you must wait a few seconds for the output voltage to stabilize. The instrument may be used before complete stabilization of the sensor bias voltage since the DC bias is blocked within the power unit.

Consult the factory for the low frequency limitations and other limitations when using the in-line charge amplifiers.

LOADING CONSIDERATIONS, IMPACT

When applying loads to the force sensor, it is important to note that the load must be distributed evenly across the force sensitive face of the force sensor.

For impact measurements, the impact cap accomplishes this adequately in most cases. During impact testing, try to control the impact point so the contact occurs close to the center of the sensor. For more massive objects impacting the sensor, a special thicker cap may need to be employed. Consult the factory for special applications such as this.

Remember also, that the impact caps may be supplied in a variety of materials to suit the exact needs of the measurement. Call the factory to ask about the many different materials available, on special order, to meet your needs.

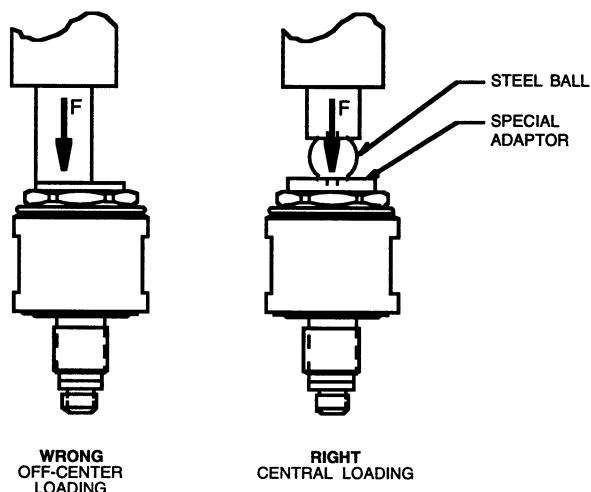

FIGURE 3
ILLUSTRATING OFF-CENTER LOADING

Figure 3 is intended to illustrate the right and the wrong way to apply loads to the 1050C. Obviously we cannot address the many different applications but we merely want to illustrate, in the most basic sense, the proper and improper ways to apply loads to these instruments for the purpose of heading off measurement problems which may be incurred by improper use.

In the illustration chosen in Figure 3, the force sensor is being loaded dynamically by a hydraulic or pneumatic ram. It is important that the force be evenly distributed, centrally, to the force sensor and the right way would be to use a steel ball to evenly load the sensor through a special adaptor which has been designed to center the ball over the force sensor.

Such adaptors are offered as a special order accessory by Dytran. Our engineering department and our state of the art machine shop are at your disposal for the design and fabrication of such adaptors. Call the factory for assistance with your particular measurement problem.

TENSILE LOADING

Figure 4 illustrates one proper way to load the 1050C in tension. Again, the forces must travel through the center of the sensor.

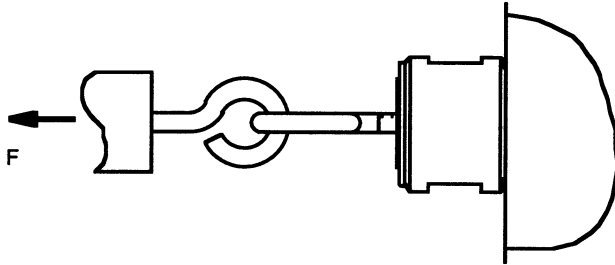

PROPER TENSILE LOADING
USING THREADED HOOK EYES

FIGURE 4
PROPER TENSILE LOADING

The arrangement shown in Figure 4 ensures that the load is applied centrally to the sensor without bending moments and transverse loading.

One important point to keep in mind when making tensile measurements is that, due to limits in the design of the internal preload structure of these sensors, the **maximum tensile force is limited to 500 Lbs.** in this series. **If this level is exceeded, the sensor may be destroyed and the load will be suddenly released.** This could engender dangerous situations for personnel and equipment if this eventuality is not fully understood.

Remember that the maximum force is the combination of both static and dynamic tensile forces. For example, if the sensor is supporting a static load of 250 Lbs., the maximum dynamic range possible is 250 Lbs, (500 - 250).

QUASI STATIC CONSIDERATIONS

Close to DC measurements are possible with the 1050C when used with a laboratory type charge amplifier such as the model 4165. These force sensors are calibrated at the factory by placing a traceable compressive force on them, (with a proving ring) then rapidly removing it and capturing the resultant step function on a digital storage oscilloscope. This is a very accurate and repeatable method for calibration of these sensors.

MAINTENANCE AND REPAIR

The sealed construction of model 1050C precludes field maintenance. Should you experience a problem with your sensor, contact the factory to discuss the problem with one of our sales engineers. If the instrument must be returned to the factory, you will be issued a Returned Materials Authorization (RMA) number so we may better follow the instrument through the evaluation process. Please do not return an instrument without first obtaining the RMA number. There is no charge for the evaluation and you will be notified of any charges before we proceed with a repair.

MODEL 6210S IMPACT CAP. MATERIAL:
17-4 PH ST. STEEL, ROCKWELL C44-45
(SUPPLIED)
MODEL 6210A (ALUM ALLOY) ALSO AVAILABLE

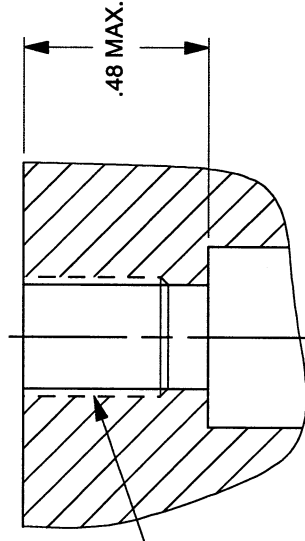
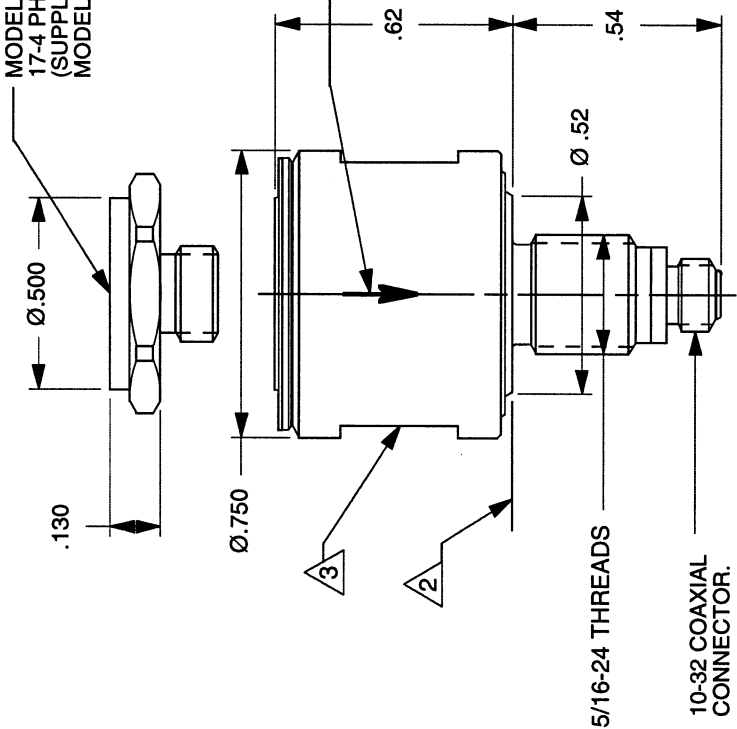

DRILL $1/8$ " ($\phi .272$) THRU
TAP 5/16-24 UNF-2B X $.360$ MIN DEPTH
PERFECT THREADS

- 3 WRENCH FLATS: $11/16$ ($.687$) ACROSS FLATS X $.31$ HIGH.
- 2 IT IS IMPORTANT THAT BOTTOM SURFACE OF SENSOR BE IN INTIMATE CONTACT. INSPECT FOR BURRS, ETC.
- 1 PREPARE FLAT SURFACE OVER $\phi .62$ MINIMUM AREA BY GRINDING, SPOTFACING, LAPPING ETC. THIS AREA MUST BE FLAT WITHIN $.001$ TIR, TYP BOTH MODELS.

EXCEPT AS OTHERWISE NOTED

ALL DIMENSIONS IN INCHES
TOLERANCE: .XXX = \pm .XX = \pm
SURFACE FINISH EXCEPT AS NOTED
BREAK EDGES TO DEBURR RADIUS OR CHAMFER
THESE DIAS \odot TO T.I.R.
FILLETES - MAX RAD.



CHATSORTH, CA.

SCALE	2X	REV.	DATE	ECN	
DATE	12/20/00	PART NO.			
DRAWN	N.C.	CHECKED	MATL		
APPROVED	<i>[Signature]</i>	R.A.	NEXT ASSEMBLY	USED ON	1050C
TITLE	OUTLINE/INSTALLATION DRAWING, MODEL 1050C				DWG NO.
					127-1050C
					SHEET 1 OF 1